



# PRESSURE CONTROL VALVES

## REMOTE CONTROL RELIEF VALVES

Remote control relief valve is connected to the vent port of the main relief valve for remote adjustment.

Max. working pressure : 250 kg/cm<sup>2</sup>

Max. flow : 2 l/min

DT-01

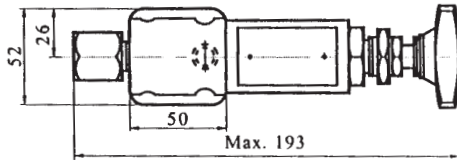

DG-01

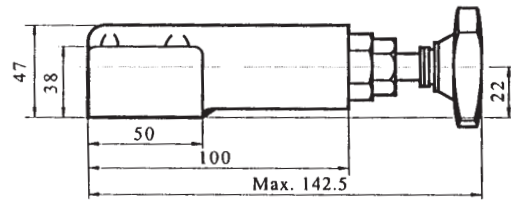
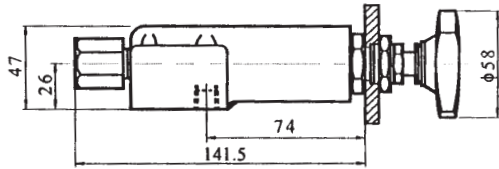
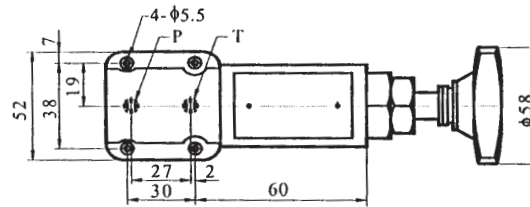

## DIRECT TYPE RELIEF VALVES

This relief valve use in small flow system or lower pressure required system.

Max. operating pressure : 210 kg/cm<sup>2</sup>.

Min. pressure setting : 5 kg/cm<sup>2</sup> (flow below 9 l/min).

Max. flow : 16 l/min.

DT-02

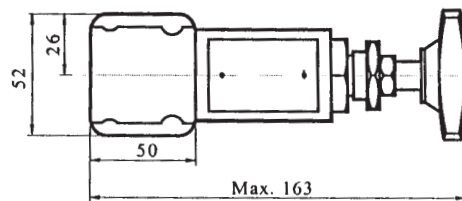

DG-02

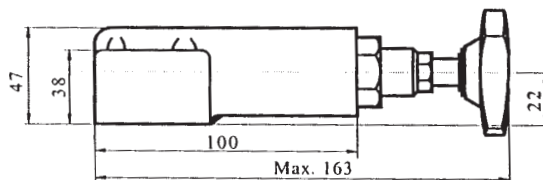
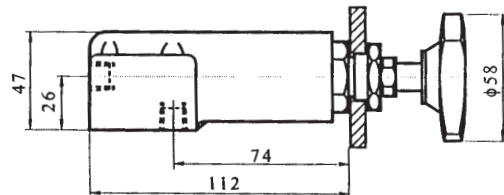
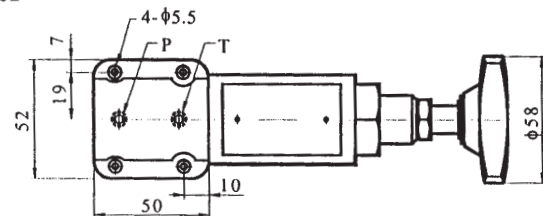

## DG-01, 02 SUBPLATE DIMENSIONS

- Mounting bolt kits are supply with valve socket head screws M5 × 45L 4 pieces.
- O-ring P9 ( 8.8 I.D. × 12.6 O.D. ) 2 pieces

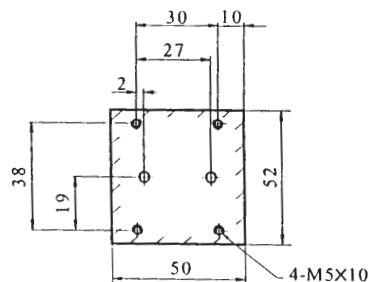

# PRESSURE CONTROL VALVES

## PILOT OPERATED RELIEF VALVES

**B** Series relief valve use in hydraulic system to limit system pressure, and protect pump against over pressure .

Max. working pressure : 250 kg/cm<sup>2</sup>

Max. flow : 04 – 100 l/min.

06 – 180 l/min.

10 – 400 l/min.

BT - 04 ,06 ,10

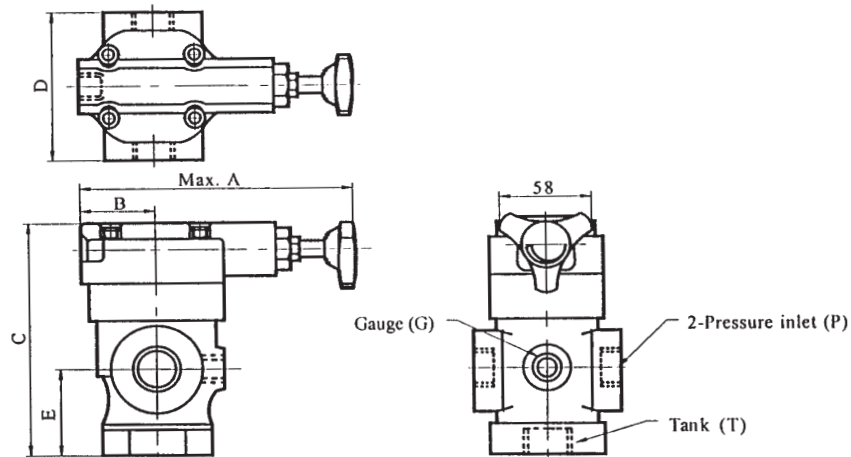

Model	A mm	B mm	C mm	D mm	E mm	P port	T port	G port
BT-04	142	33.0	111	84.5	42	1/2"	1/2"	1/4"
BT-06	165	38.5	140	103.0	51	3/4"	3/4"	
BT-10			183	130.0	68	1 1/4"	1 1/4"	

BG - 03 ,06 ,10

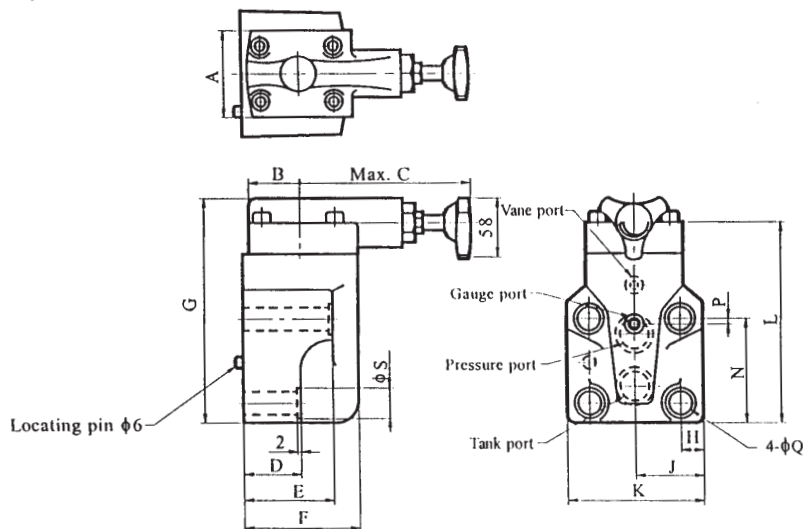

Model	A mm	B mm	C mm	D mm	E mm	F mm	G mm	H mm	J mm	K mm	L mm	N mm	P mm	Q mm	S mm
BG-03	75	40	105	57	78	78.0	137	14.1	41	82	117	77.0	22.0	13.5	21
BG-06				40	60		161	17.0	52	104	141	83.5	4.5	17.5	26
BG-10	85	45	103	47	67	87.5	195	20.7	62	124	175	110.0	6.0	21.5	32