

FIXED DISPLACEMENT VANE PUMPS

This series pump possesses vane construction with special cam ring for low noise, high efficiency longer life-span and more stable performance.

Model	Flow cc/rev	Drive speed		Max. pressure kg/cm ²	Model	Flow cc/rev	Drive speed		Max. pressure kg/cm ²
		Max.	Min.				Max.	Min.	
DS-12	4.2	2200	600	70	PV2R1-08	8.0	750		210
DS-13	7.0				PV2R1-10	9.4			
DS-14	12.2				PV2R1-12	12.2			
50T-07	6.8	PV2R1-14			13.7				
50T-12	11.6	PV2R1-19			18.6				
50T-17	16.5	PV2R1-23			22.7				
50T-23	22.9	PV2R1-25			25.3	1800	600	210	
50T-26	25.9	PV2R1-31			31.0				
50T-36	36.0	PV2R2-26			25.8				
50T-39	38.8	PV2R2-33			33.1				
150T-48	47.7	PV2R2-41			41.3				
150T-61	61.1	PV2R2-47			47.2				
150T-75	74.9	1200	800	140	PV2R2-53	52.5			210
150T-94	93.6				PV2R2-59	58.2			
150T-116	115.6				PV2R2-65	64.7			
PVR50-20	16.6	PV2R3-76			76.0	160			
PVR50-23	18.6	PV2R3-94			93.6				
PVR50-26	22.2	PV2R3-116			115.6				
PVR50-30	25.0								
PVR50-36	30.6								

ORDERING CODE

FIXED DISPLACEMENT VANE PUMP

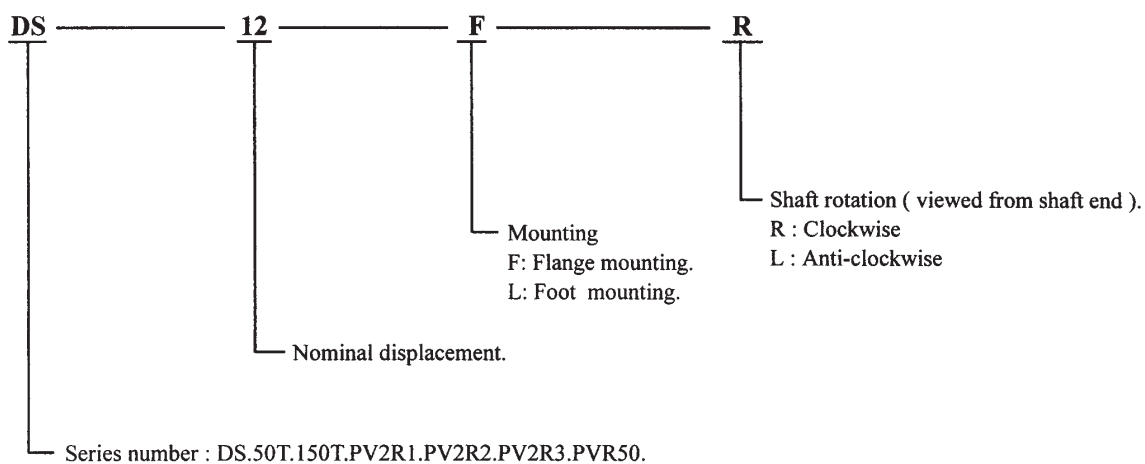

FIXED DISPLACEMENT VANE PUMPS

DS SERIES

Maximum pressure : 70 kg/cm²

Flow capacity : DS-12 : 7.7 l/min. (at 1800 r.p.m. / 0 kg/cm²)

13 : 12.6

14 : 22.1

Weight : Foot type 4.4 kgs.

Flange type 3.0 kgs.

DS

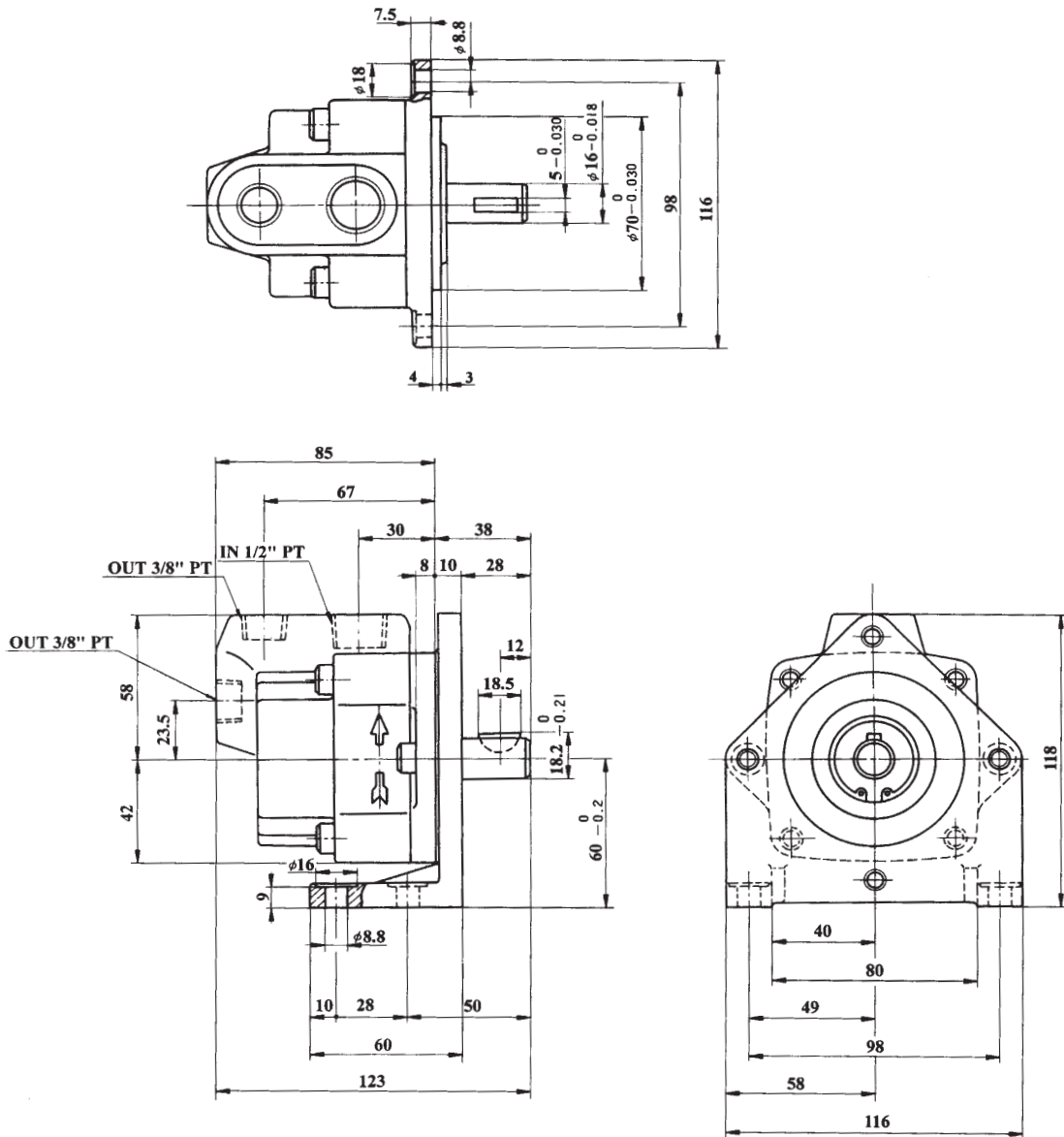

FIXED DISPLACEMENT VANE PUMPS

50T/150T SERIES

Maximum pressure : 70 kg/cm²

Flow capacity : 50T-07 : 6.8 l/min. 150T-48 : 47.7 l/min (at 1000 r.p.m.)

12 : 11.6 61 : 61.1

17 : 16.5 75 : 74.9

23 : 22.9 94 : 93.6

26 : 25.9 116 : 115.6

36 : 36.0

39 : 38.8

Weight : Foot type 50T : 10.5 kgs.

150T : 26.1 kgs.

Flange type 50T : 9.0 kgs.

150T : 25.0 kgs.

50T

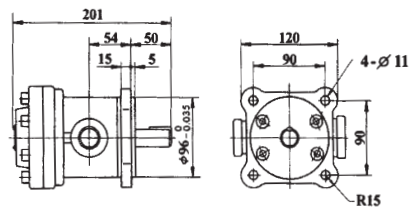
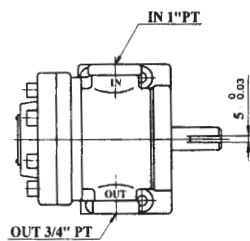

Flange type

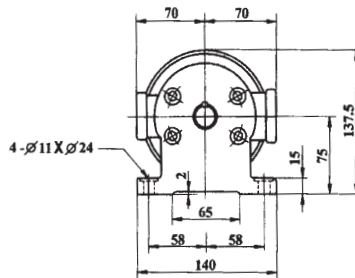
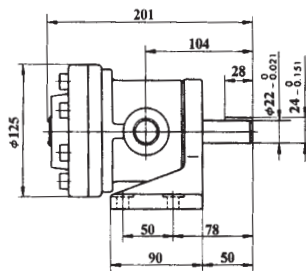

150T

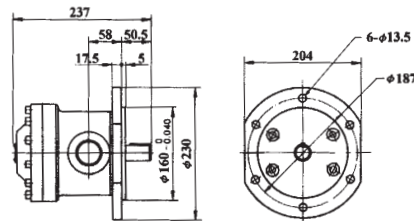
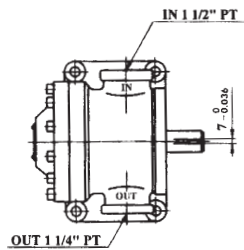

Flange type

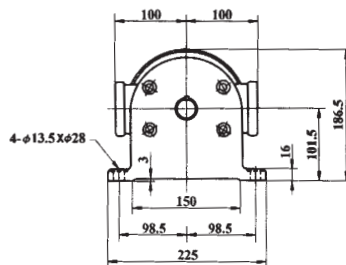
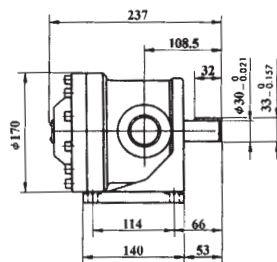

FIXED DISPLACEMENT VANE PUMPS

50T-07

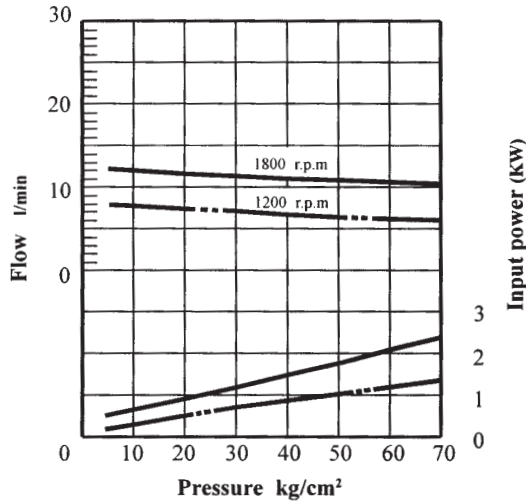

50T-12

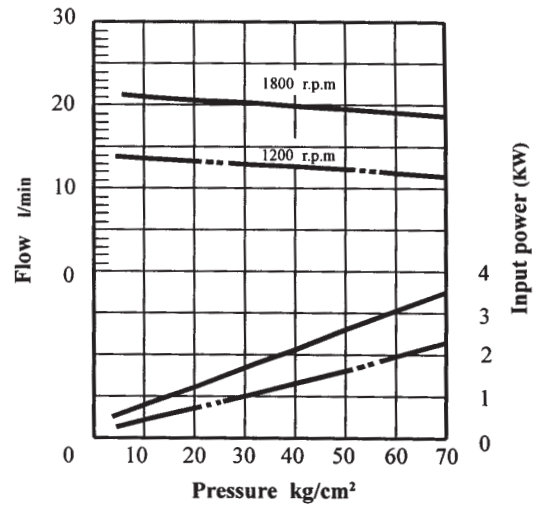

50T-17

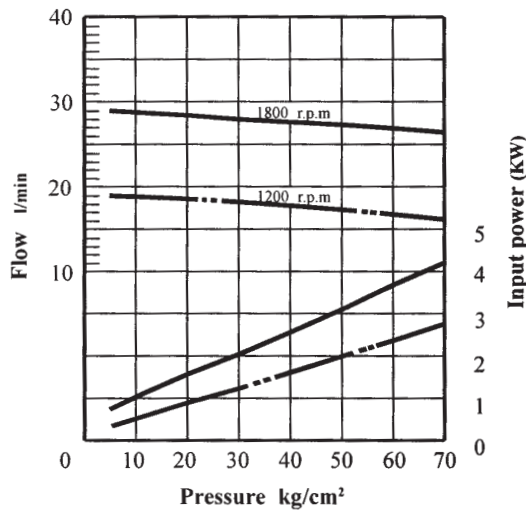

50T-23

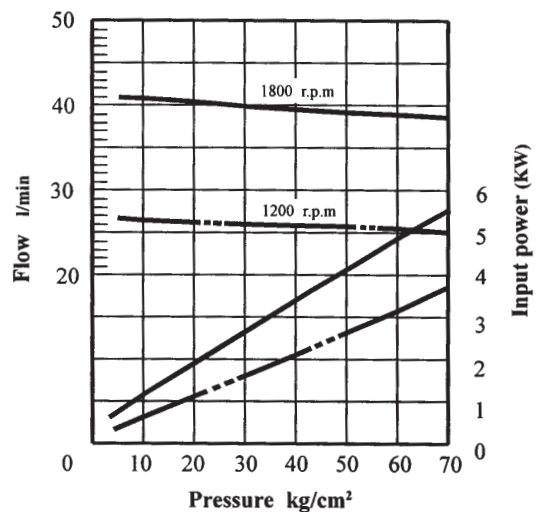

50T-26

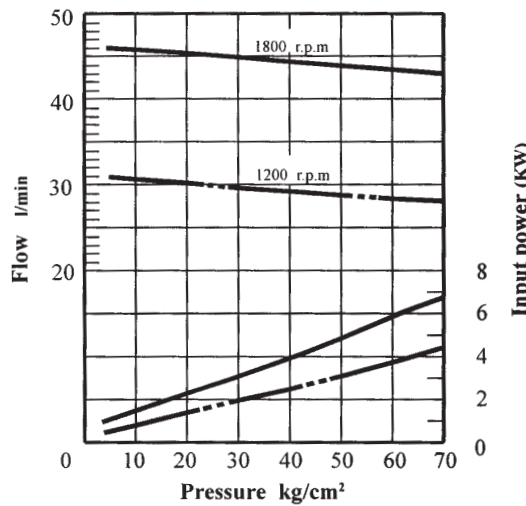

50T-36

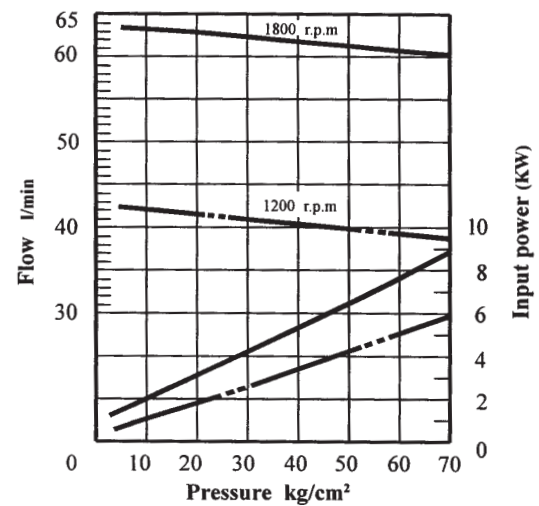

FIXED DISPLACEMENT VANE PUMPS

50T-39

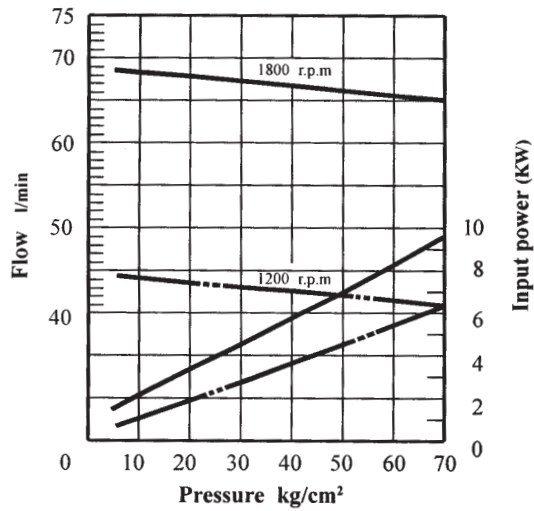

150T-48

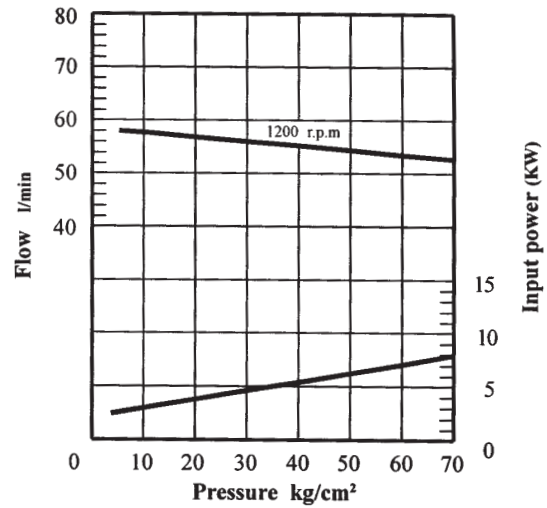

150T-61

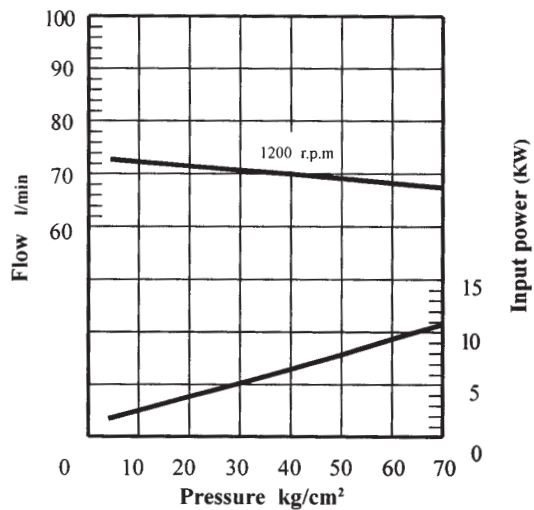

150T-75

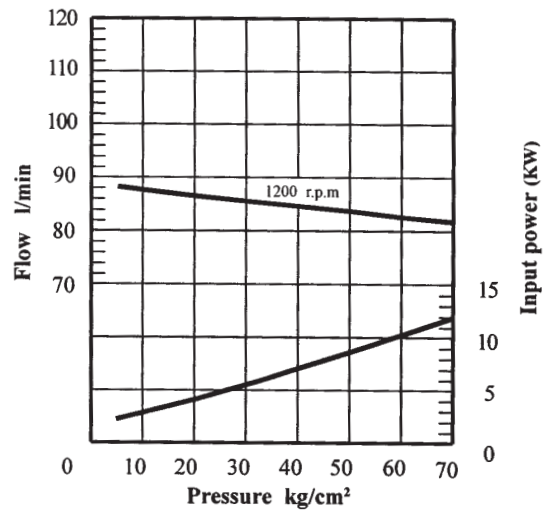

150T-94

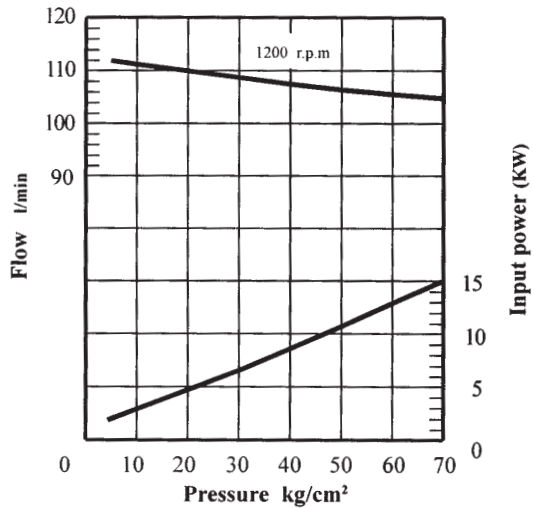

150T-116

