

PILOT OPERATED CHECK VALVES

Pilot operated check valves are used to direct free flow in one direction. Flow may pass in the opposite direction when pilot pressure unseats the poppet.

Pilot operated check valve		Max. flow rated l/min	Max. working pressure kg/cm ²	Weight kg	
Subplate type	Thread type				
CPDG-03	CPDT-03	50	210	4.5	3.4
CPDG-06	CPDT-06	125		7.0	5.2
CPDG-10	CPDT-10	300		12.0	11.6

ORDERING CODE

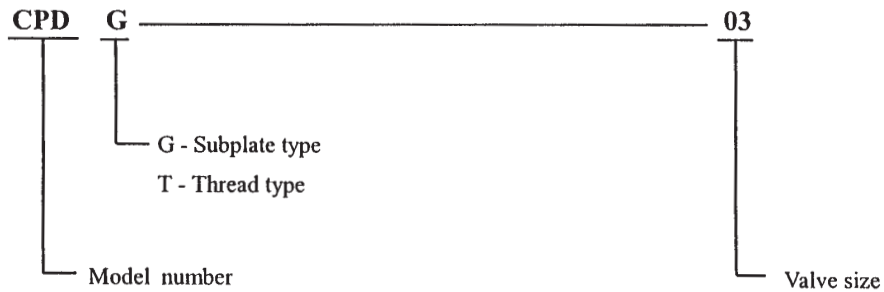

CPDT - 03 , 06 , 10

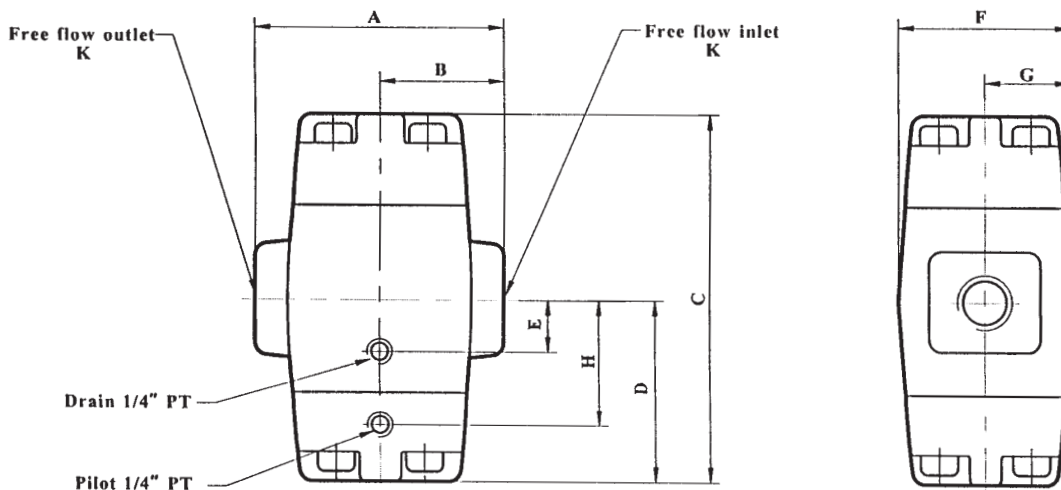

Model	A mm	B mm	C mm	D mm	E mm	F mm	G mm	H mm	K PT	Weight kg
CPDT-03	80	40	150.5	75	21	68	35.5	58	3/8"	3.4
CPDT-06	96	48	168.0	84	26	78	38.0	70	3/4"	5.2
CPDT-10	140	70	208.0	104	35	92	45.0	84	1 1/4"	11.6

PILOT OPERATED CHECK VALVES

CPDG - 03 , 06

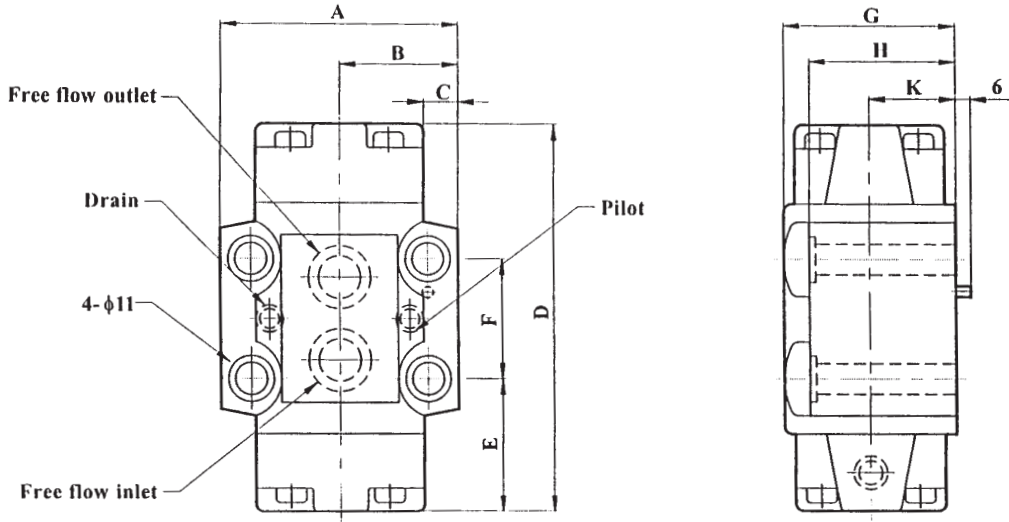

Model	A mm	B mm	C mm	D mm	E mm	F mm	G mm	H mm	K mm	Mounting bolt mm	Weight kg
CPDG-03	92	46.0	13.6	150.5	54	42.9	70.5	59	34.5	4-M10 X 70L	5.0
CPDG-06	103	51.5	11.5	174.0	57	60.3	85.0	68	40.0	4-M10 X 80L	7.8

CPDG - 10

